

**FIGURE 328**  
**POST AND FRAME WALL SECTION**  
**(NO SCALE)**

**SECTION 328  
POST FRAME ACCESSORY  
STRUCTURES**

**328.1 Post frame accessory structures.** The following requirements serve as minimum standards for post and frame structures within all of the following structural limitations:

1. Residential accessory structures,
2. Single story,
3. Solid exterior structural sheathing or metal roof, and solid wall panels,
4. No attic storage,
5. Maximum building width of thirty six feet including the overhang,
6. Maximum wall height of sixteen feet,
7. Maximum mean roof height of twenty feet, and
8. Maximum post spacing of eight feet.

Post and frame structures and portions thereof outside the above structural limitations of this standard shall be accompanied by structural calculations as required by the residential building official or designed under the provisions of Section 106.5 of the Residential Code of Ohio (RCO). Post and frame structures shall comply with the structural design requirements of Section 301 of the RCO.

**328.2 Definition.** Post frame accessory structures consist of primary members (wood posts, beams & single span roof trusses or ceiling joist and rafters) and secondary members (wood roof purlins, wall girts, bracing & sheathing) where all loads are transmitted from the sheathing and the secondary members to the primary members which transfer all combined loads to the soil through vertical posts bearing on footings embedded in the ground. See Figure 328.

**328.3 Footings and foundations.** Footings and foundations shall comply with applicable provisions of 401. Post frame structures shall have poured in-place concrete footings installed below all posts. The top of the footing shall be a minimum of 48 inches below finished grade and have footing diameters complying with Table 328.3.

**TABLE 328.3  
POST FRAME PIER FOOTING DIAMETERS<sup>1 2 3 4</sup>**

	BUILDING WIDTH (length of truss) INCLUDING OVERHANG (feet)			
	24	28	32	36
Diameter (inches) 20# roof snow load	18	20	22	22
Diameter (inches) 30# roof snow load	18	22	24	26

- J. Pier footing thickness shall be a minimum one-half of the diameter of the footing.
2. Based upon 2000 PSF soil bearing capacity and truss loads of 20 or 30 PSF live or snow load top chord, 10 PSF dead load top chord, 5 PSF dead load on the bottom chord and no live load on the bottom chord.
3. Fractional widths shall be rounded to the next higher pier footing diameter.
4. Table not to be used in Ohio case study areas.

**328.4 Post and wall construction.** Posts shall be three (3) ply unspliced, reinforced spliced or solid wood and shall not be less than 4 inch by 6 inch nominal size. Posts shall comply with the requirements of Section 317.

**328.4.1 Uplift protection:** Posts shall have uplift protection by one of the following methods:

1. Two 2 x 6 x 12 inch post uplift protection blocks attached to each side of the base of the post. The post uplift blocks shall be placed horizontally, attached per Table 328.7 and comply with Section 317.
2. 12 inch high, concrete collar poured on top of footing around the post, with 2-#5 x 9 inch rebar placed through the post at 3 inches and 9 inches from bottom of post in opposite directions. The rebar ends must be 1 1/2 inches from the soil. See Figure 328.1.

**328.4.2 Post Spacing.** The maximum spacing for posts shall be (eight) feet on center.

**328.4.3 Skirt Boards.** Skirt boards shall be treated lumber meeting the requirements of Section 317 and attached per Table 328.7.

**328.4.4 Wall girts.** Wall girts shall be not less than 2 x 4 inches nominal and spaced not more than twentyfour (24) inches on center.

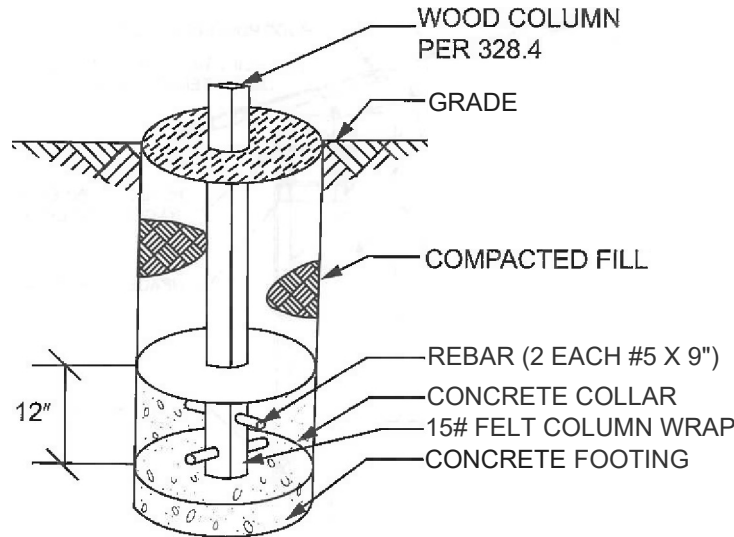

FIGURE 328.1  
POST UPLIFT PROTECTION EXCEPTION  
(NO SCALE)

**328.4.1 Load bearing beams and headers:** Load bearing beams and headers shall comply with Table 502.5(1).

**Exceptions:**

1. Bearing beams are not required if the trusses or ceiling joists and rafters bear directly on the posts.
2. Headers in the gable-end wall which do not support more than five square feet of wall area per lineal foot of header shall be sized per Table 328.4.5.

TABLE 328.4.5  
GABLE END HEADER SIZES

Opening Width (feet)	10	12	16
Header Size (inches)	2-2 x 8	2-2 x 10	2-2 x 12

**328.4.6 Bracing Wall** shall be provided to resist all racking and shearing forces and must comply with the applicable provisions of section 602.10 or by installing 2x6 diagonal cross braces in the bays between adjacent posts as described in this section. The diagonal cross braces shall be placed from the top header or girt to the next adjacent post at the skirt board. The cross bracing shall be placed or installed on all sides of the building and shall be spaced at a maximum of 25 feet on center and within 12 feet of the corners of the building and attached per Table 328.7. Any splices of the diagonal brace required due to excessive length, must lap over two consecutive wall girts.

**328.4.7 Beams supporting trusses or rafters and ceiling joists attachment to column.** Bearing beams supporting roof trusses or rafters and ceiling joists shall be connected to the posts by one of the following methods:

1. Bolts that are 1/2 inch diameter through-bolted to the side of the post;

2. Bolts that are 1/2 inch diameter, directly attached to a 3-ply post notch, enclosing the truss or rafter at the top of post; or
3. Other fasteners with minimum shear or withdraw values stated in Table 328.4.7

**328.4.7.1 Number of fasteners.** The minimum numbers of through bolts or other fasteners with minimum shears or withdraw values required per Table 328.4.7.

TABLE 328.4.7  
BEAM OR TRUSS CONNECTION AT POSTS MINIMUM FASTENERS OR TOTAL SHEAR OR WITHDRAW VALUES <sup>a,b,e</sup>

	BUILDING WIDTH (Length of Truss) INCLUDING OVERHANG (feet)			
	24	28	32	36
Shear or withdraw (pounds) 20 lb snow load	3360	3920	4480	5040
Number of Bolts, 20 lb roof snow load	2	2	2	3
Shear or withdraw (pounds) 30 lb roof snow load	4320	5040	5760	6480
Number of Bolts, 30 lb roof snow load	2	3	3	3

- a. Based upon truss loads of 20 or 30 PSF live or snow load top chord, 10 PSF dead load top chord, 5 PSF live load on the bottom chord and no live load on the bottom chord.
- b. Based upon post spacing at intervals not exceeding 8 feet.
- c. When beams are attached at each side of the column and fasteners do not extend through both beams such as through-bolts, the required values are one-half the amount shown above for each beam.

**328.5 Roof purlins.** Roof purlins shall be a minimum of 4x2 SPF#2 laid flat for spans up to 4 feet, and 4x2 SPF#2 laid on edge for spans up to 8 feet. Roof purlins shall be spaced not more than 24 inches on center.

**328.6 Knee bracing.** A 2 x 6 brace shall extend from the post to the top chord of the truss or rafter adjacent to the post at a

45 degree angle. The vertical distance down from the bottom chord of the truss or ceiling joist to the point where the brace attaches to the posts shall be in compliance with Table 328.6 as shown on Figure 328. Trusses or rafters must be spaced such that they align with the post intervals. Attachment of knee brace shall be per Table 328.7.

**TABLE 328.6  
KNEE BRACE VERTICAL DISTANCE**

Wal/Height	Vertical Dimension
8'-0" and 9'-0"	1'-6"
10'-0" and 11'-0"	2'-0"
12'-0" and 13'-0"	3'-0"
14'-0" through 16'-0"	4'-0"

**328.7 Attachment details.** Structural fastener details for post and frame buildings shall comply with Table 328.7.

**328.8 Roof trusses.** Engineered roof trusses, where used, shall be accompanied by drawings sealed by the registered design professional responsible for their preparation and shall be submitted to the residential building official for approval prior to the framing inspection. The truss design shall comply with Sections 802.10 and 802.11 and shall account for all loads imposed on the truss as a result of the prescriptive requirements of this section.

**TABLE 328.7  
STRUCTURAL FASTENERS**

FASTENER SCHEDULE FOR STRUCTURAL MEMBERS		
Description of Building Element	Number and Type of Fastener	Attachment type
Uplift blocking to post	5-16d Hot Dipped Galvanized	Each block
Skirt board to post	2-16d Hot Dipped Galvanized	Face nail
Wall girt to post	2-16d Hot Dipped Galvanized	Face nail
Diagonal cross bracing to post	2-16d Hot Dipped Galvanized	Face nail
Diagonal cross bracing to skirt board	2-10d Hot Dipped Galvanized	Face nail
Diagonal cross bracing to wall girts, beam, or header	2-10d	Face nail
Knee brace to post	3-16d Hot Dipped Galvanized	Face nail
Knee brace to top chord of truss or rafter	3-10d	Face nail
Knee brace to bottom chord of truss or ceiling joist	3-10d	Face nail
Roof purlin to truss or rafter with span of 2' or 4'	2-16d	Face nail
Roof purlin to truss or rafter with span of 8'	Mechanical fastener with uplift protection greater than 225 pounds.	Per manufacturer installation manual